



MS200/300/400 Magnetic Stirrer

Instruction Manual

Introduction

Thank you for selecting the MS series magnetic stirrer. This manual provides a step-by-step guide to help you operate the instrument, please carefully read the following instructions before use.

Specifications

- Maximum Stirring Volume: 2 Liter (H₂O)
- Stirring Speed: 0 to 1250rpm
- Temperature Range:

MODEL	RANGE
MS200	---
MS300	Room Temperature to 300°C
MS400	Room Temperature to 400°C

- Timer Range: 0 to 999 minutes
- Top Plate Size: 135(L)×135(W)mm
- Power Requirements: AC 220V/50Hz
- Dimensions: 230(L)×180(W)×120(H)mm
- Weight: 2.2kg

Unpacking

The following list describes the standard accessories of stirrer. After the unpacking, please check all accessories are complete. If any are damaged or missing, please contact nearest distributor.



Temperature Probe (Only for MS300 and 400 magnetic stirrer)



Stir Bar

Stirring the liquids

- Before plugging the plug into the power outlet, ensure that local mains power voltage matches the stirrer requirements.
- Place the stir bar into the container, press the power switch to ON position, the display will light up.

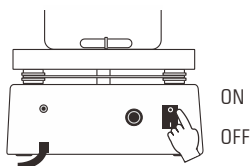

2. Press ▲ or ▼ key to set the desired stirring speed, the speed bar on screen will show current run status.

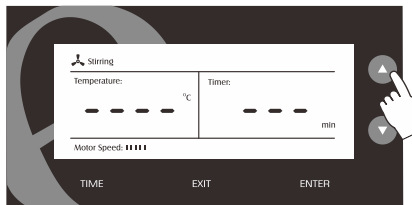

If the stirrer does not working, please move the container slightly, ensure that stir bar is in container's center.

Setting the stirring time

MS series magnetic stirrer has a built-in timer that allows you to set the stirring time from 1 to 999 minutes.

1. Press TIME key to enter the setting mode, the display shows "000 min".

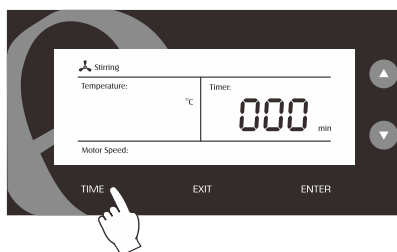

2. Press ▲ or ▼ key to set the stirring time, press ENTER key to confirm. Timer will begin countdown until it gets to zero, the stirrer stops the stirring simultaneously.



If you want to exit the setting mode, press EXIT key, the stirrer will return to stirring mode.

Heating the liquids (Only for MS300 or MS400)

1. Insert the connector of temperature probe into the corresponding connector socket on the rear panel.

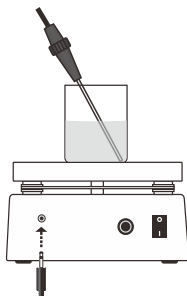

- Place the temperature probe into the liquid, the display shows temperature value.
- Press °C key to enter the temperature setting mode.

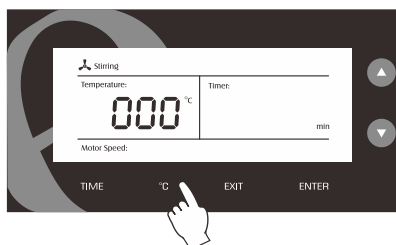

- Press ▲ or ▼ key to set the target temperature.
- Press ENTER key to confirm, the stirrer is now begin heating.

NOTE:

- Please ensure that temperature probe is connected to socket, the hotplate will not heat if the probe is not attached.
- While heating a liquid the temperature probe must be immersed, otherwise the hotplate will heat continuously and will go into a fault condition.
- During the heating mode, the "Heating" indicator will successively show as follows:



- When the liquid reached the setting temperature, the "heating" indicator will flashing continuously.



EXIT THE HEATING MODE:



Press EXIT key in the heating mode, the stirrer will stop heating immediately.

Temperature Calibration

During the heating, if the temperature reading displayed differs from that of an accurate thermometer, please follow the steps below to calibrate the stirrer.

- Switch off the stirrer.
- Press and hold the ▲ and ▼ key for 3 seconds, then switch on the stirrer. The display will show current temperature value.
- Press ▲ or ▼ key to set the temperature value, press ENTER key to confirm. Calibration is completed.

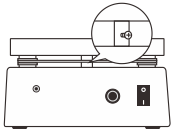
Troubleshooting

FAILURE	CAUSE
Stir bar does not working	 <ul style="list-style-type: none">▪ Check the screw under the top plate are loose.▪ Container is not in the center of top plate.
Can not heating	 <ul style="list-style-type: none">▪ The temperature probe is not connect to stirrer.▪ Heater has damaged.

Hazardous Substance Statement

Bante Instruments is committed to the reduction and eventual elimination of all hazardous substances in both the manufacturing process and finished products we supply. We have an active manufacturing and procurement program to minimize and eliminate the use of harmful heavy metals such as cadmium, lead, mercury and the like. New technologies and design parameters are also promoting these efforts and we expect to have little or no such materials in our product in the coming years. We welcome our customer suggestions on how to speed up these efforts.



Warranty

The warranty period for magnetic stirrer is one year from the date of shipment. Above warranty does not cover stir bar and temperature probe. For more information, please contact nearest authorized distributor.



BANTE INSTRUMENTS LIMITED

E-mail: banteinstruments@yahoo.com

Phone: +8621-6404-1598

Website: www.bante-china.com